

Technics

AV control stereo receiver

SA-GX550

SA-GX350

Operating Instructions



The photographs show SA-GX550.

Before connecting, operating or adjusting this product, please read these instructions completely.

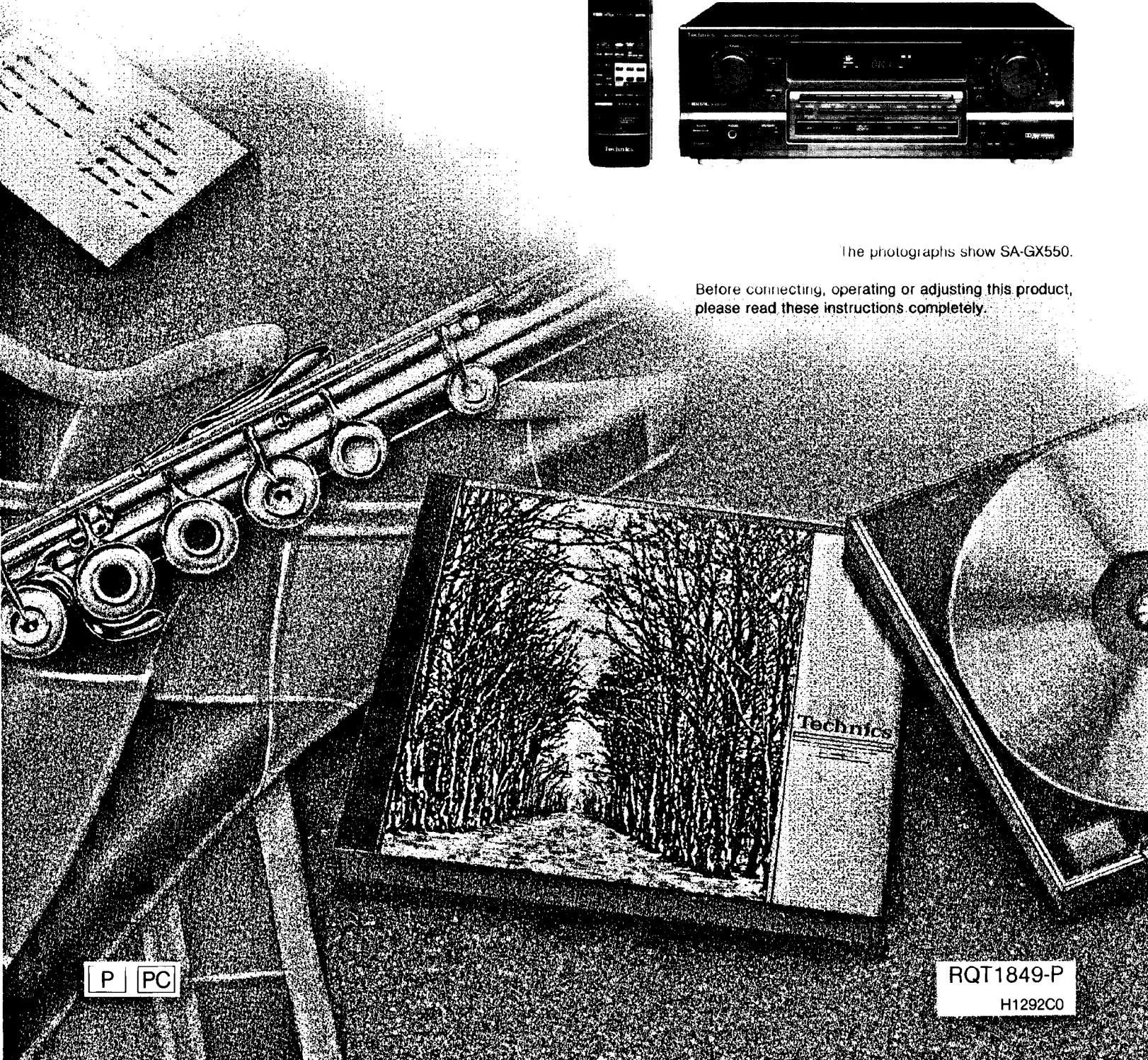

P | PC

RQT1849-P
H1292C0

Dear Customer

Thank you for purchasing this Technics product.
For optimum performance and safety, please read
these instructions carefully.

These operating instructions are applicable to models SA-GX550 and SA-GX350.

These operating instructions, however, are intended primarily
for model SA-GX550.

The model number and serial number of this product can be
found on either the back or the bottom of the unit.

Please note them in the space provided below and retain
them for future reference.

MODEL NUMBER.....
SERIAL NUMBER.....

WARNING:

**TO REDUCE THE RISK OF FIRE OR
ELECTRIC SHOCK, DO NOT EXPOSE THIS
APPLIANCE TO RAIN OR MOISTURE.**

CAUTION:

**TO PREVENT ELECTRIC SHOCK MATCH
WIDE BLADE OF PLUG TO WIDE SLOT,
FULLY INSERT.**

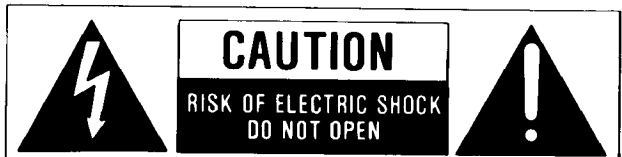

CAUTION: TO REDUCE THE RISK OF
ELECTRIC SHOCK, DO NOT
REMOVE SCREWS.
NO USER-SERVICEABLE
PARTS INSIDE.
REFER SERVICING TO QUALIFIED
SERVICE PERSONNEL.



The lightning flash with arrowhead symbol,
within an equilateral triangle, is intended to
alert the user to the presence of uninsulated
"dangerous voltage" within the product's
enclosure that may be of sufficient magnitude
to constitute a risk of electric shock to persons.



The exclamation point within an equilateral
triangle is intended to alert the user to the
presence of important operating and main-
tenance (servicing) instructions in the literature
accompanying the appliance.

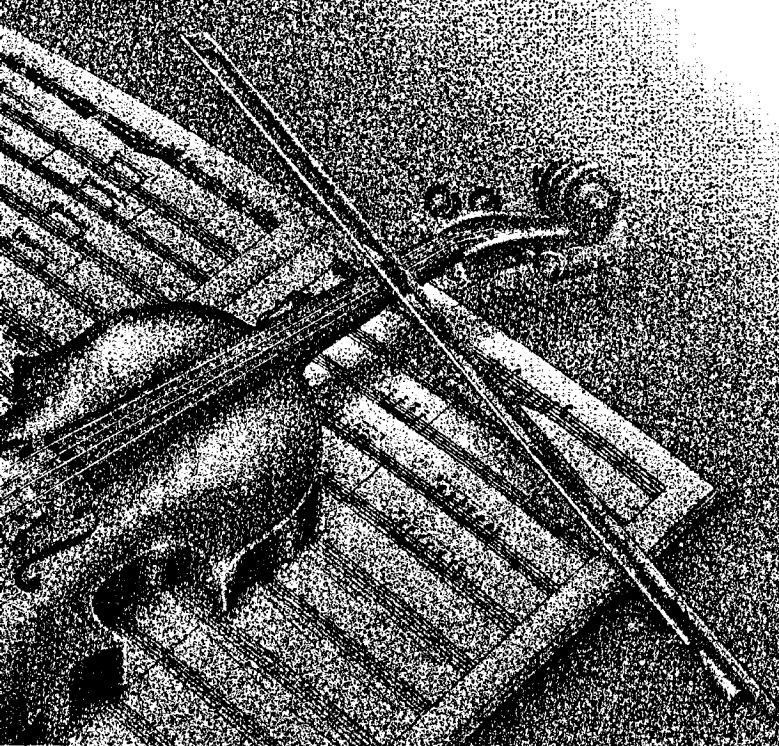

Table of contents

Before use

Suggestions for safety	4
Safety	4
Installation	4
Maintenance	4
Service	4
Listening caution	5
Accessories	5
Front panel controls	6
Control section	6
Display section	7

Connections

Equipment connections	8
Connecting audio equipment	8
Connecting video equipment	9
Antenna connections	10
FM indoor antenna	10
FM outdoor antenna	10
AM loop antenna	11
AM outdoor antenna	11
Speaker connections	12
Placement of speakers	12
Connection of front speakers	12
Connection of rear speakers	13
Connection of center speaker	13

Listening

Basic operations	14
To listen to a desired audio source while watching video picture	15
To adjust the sound balance	15
To mute the sound level	15
To emphasize low-frequency sound SA-GX550 only	15
To adjust the tone quality	15
When listening through headphones	15
Listening to radio broadcasts	16
Direct access tuning	16
Sequential tuning For SA-GX550	17
Sequential tuning For SA-GX350	18
Preset tuning	18

Adjusting the sound field

Enjoying sound with DOLBY PRO LOGIC	21
SURROUND	21
3 STEREO	21
Setting the center mode	21
Adjusting the delay time SA-GX550 only	22
Adjusting the output level of each speaker	22
Enjoying with SURROUND or 3 STEREO	23

Recording

Making a recording	24
Tape recording on the tape deck or digital compact cassette (DCC)	24
Recording from VCR 2 to VCR 1	25
VCR (VCR 1) recording from an audio source	25
To record picture from VCR 2 and sound from a different audio source	26

When there seems to be a problem

Product service	26
Product information	26
Troubleshooting guide	27

Reference

Technical specifications	Back cover
---------------------------------------	-------------------

Suggestions for safety

Before using this unit please read these operating instructions carefully. Take special care to follow the warnings indicated on the unit itself as well as the safety suggestions listed below. Afterwards keep them handy for future reference.

Safety

1. **Power Source** -- The unit should be connected to power supply only of the type described in the operating instructions or as marked on the unit.
2. **Polarization** -- If the unit is equipped with a polarized AC power plug (a plug having one blade wider than the other), that plug will fit into the AC outlet only one way. This is a safety feature. If you are unable to insert the plug fully into the outlet, try reversing the plug. If the plug should still fail to fit, contact your electrician to replace your obsolete outlet. Do not defeat the safety purpose of the polarized plug.
3. **Power Cord Protection** -- AC power supply cords should be routed so that they are not likely to be walked on or pinched by items placed upon or against them. Never take hold of the plug or cord if your hand is wet, and always grasp the plug body when connecting or disconnecting it.
4. **Nonuse Periods** -- When the unit is not used, turn the power off. When left unused for a long period of time, the unit should be unplugged from the household AC outlet.

Installation

Environment

1. **Outdoor Antenna Grounding** -- If an outside antenna is connected to the receiver, be sure the antenna system is grounded so as to provide some protection against voltage surges and built-up static charges. Section 810 of the National Electrical Code, ANSI/NFPA No. 70-1990, provides information with respect to proper grounding of the mast and supporting structure, grounding of the lead-in wire to an antenna discharge unit, size of grounding conductors, location of antenna-discharge unit, connection to grounding electrodes, and requirements for the grounding electrode. See figure below.

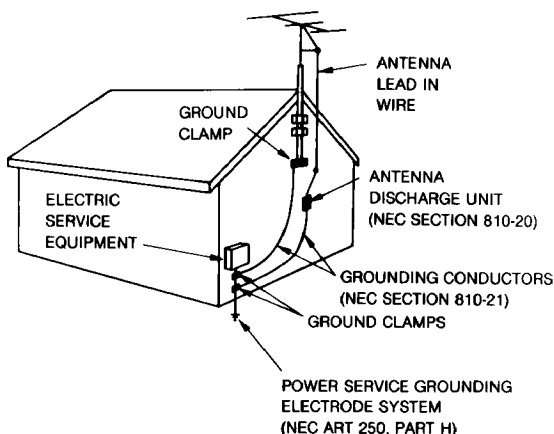

NEC - NATIONAL ELECTRICAL CODE

2. **Water and Moisture** -- Do not use this unit near water -- for example, near a bathtub, washbowl, swimming pool, or the like. Damp basements should also be avoided.
3. **Heat** -- The unit should be situated away from heat sources such as radiators and the like. It also should not be placed in temperatures less than 5°C (41°F) or greater than 35°C (95°F).

Placement

1. **Ventilation** -- The unit should be situated so that its location or position does not interfere with its proper ventilation. Allow 10 cm (4") clearance from the rear of the unit.
2. **Foreign Material** -- Care should be taken so that objects do not fall into and liquids are not spilled into the unit. Do not subject this unit to excessive smoke, dust, mechanical vibration, or shock.
3. **Magnetism** -- The unit should be situated away from equipment or devices that generate strong magnetism.
4. **Stacking** -- Do not place heavy objects, other than system components, on top of the unit.
5. **Surface** -- Place the unit on a flat, level surface.
6. **Carts and Stands** -- The unit should be used only with a cart or stand that is recommended by the manufacturer. The unit and cart combination should be moved with care. Quick stops, excessive force, and uneven surfaces may cause the unit and cart combination to overturn.
7. **Wall or Ceiling Mounting** -- The unit should not be mounted to a wall or ceiling, unless specified in this operating instructions.



Maintenance

Clean the cabinet, panel and controls with a soft cloth lightly moistened with mild detergent solution.

Do not use any type of abrasive pad, scouring powder or solvent such as alcohol or benzine.

Service

1. **Damage Requiring Service** -- The unit should be serviced by qualified service personnel when:
 - (a) The AC power supply cord or the plug has been damaged; or
 - (b) Objects have fallen or liquid has been spilled into the unit; or
 - (c) The unit has been exposed to rain; or
 - (d) The unit does not appear to operate normally or exhibits a marked change in performance; or
 - (e) The unit has been dropped, or the enclosure damaged.
2. **Servicing** -- The user should not attempt to service the unit beyond that described in the operating instructions. All other servicing should be referred to qualified service personnel.

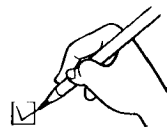

Please check and identify the supplied accessories

Listening caution



Selecting fine audio equipment such as the unit you've just purchased is only the start of your musical enjoyment. Now it's time to consider how you can maximize the fun and excitement your equipment offers. This manufacturer and the Electronic Industries Association's Consumer Electronics Group want you to get the most out of your equipment by playing it at a safe level. One that lets the sound come through loud and clear without annoying blaring or distortion—and, most importantly, without affecting your sensitive hearing.

Sound can be deceiving. Over time your hearing "comfort level" adapts to higher volumes of sound. So what sounds "normal" can actually be loud and harmful to your hearing.

Guard against this by setting your equipment at a safe level BEFORE your hearing adapts.

To establish a safe level:

- Start your volume control at a low setting.
- Slowly increase the sound until you can hear it comfortably and clearly, and without distortion.

Once you have established a comfortable sound level:

- Set the dial and leave it there.

Taking a minute to do this now will help to prevent hearing damage or loss in the future. After all, we want you listening for a lifetime.

We Want You Listening For A Lifetime

Used wisely, your new sound equipment will provide a lifetime of fun and enjoyment. Since hearing damage from loud noise is often undetectable until it is too late, this manufacturer and the Electronic Industries Association's Consumer Electronics Group recommend you avoid prolonged exposure to excessive noise. This list of sound levels* is included for your protection.

*The level used here is different from that displayed on the system's display.

Decibel

Level	Example
30	Quiet library, soft whispers
40	Living room, refrigerator, bedroom away from traffic
50	Light traffic, normal conversation, quiet office
60	Air conditioner at 20 feet, sewing machine
70	Vacuum cleaner, hair dryer, noisy restaurant
80	Average city traffic, garbage disposals, alarm clock at two feet

THE FOLLOWING NOISES CAN BE DANGEROUS UNDER CONSTANT EXPOSURE

90	Subway, motorcycle, truck traffic, lawn mower
100	Garbage truck, chain saw, pneumatic drill
120	Rock band concert in front of speakers, thunderclap
140	Gunshot blast, jet plane
180	Rocket launching pad

Information courtesy of the Deafness Research Foundation.

- AC power supply cord 1 pc.
(For USA: SJA172-1)
(For Canada: SJA172)

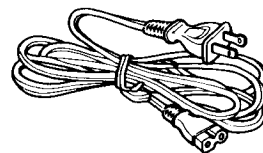

- AM loop antenna set (SPB1163T)
• AM loop antenna 1 pc.
• AM antenna holder 1 pc.
• Screws 2 pcs.

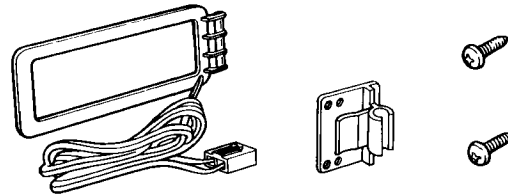

- FM indoor antenna (RSA0006) 1 pc.

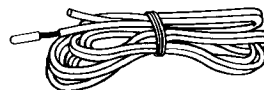

- Remote control transmitter 1 pc.
For SA-GX350 (RAK-SA006MH) **For SA-GX550** (RAK-SA901MH)

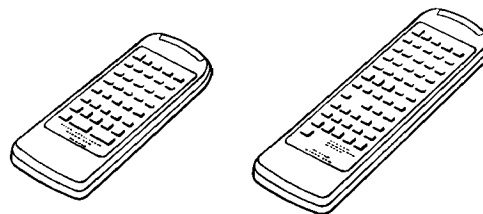

For details on remote control transmitter operation, refer to "How to use the remote control transmitter" in the separate booklet.

- Batteries (UM-4, "AAA", R03) 2 pcs.

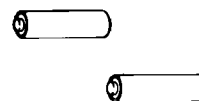

Front panel controls

Control section

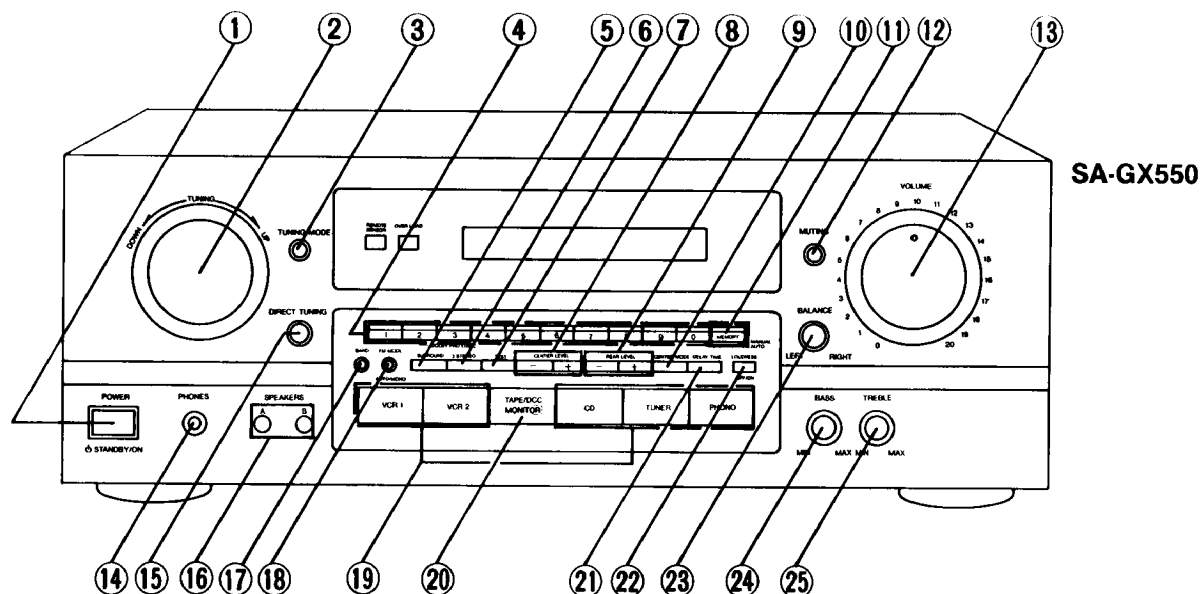

No.	Name	Ref. page
①	Power switch (POWER)	14
②	For SA-GX550 Tuning control (TUNING)	17
	For SA-GX350 Tuning buttons (TUNING)	18
③	Tuning mode select button (TUNING MODE) SA-GX550 only	17
④	Numeric buttons (1-0)	16,19,20
⑤	DOLBY PRO LOGIC SURROUND ON/OFF button (SURROUND)	21,22,23
⑥	DOLBY PRO LOGIC 3 STEREO ON/OFF button (3 STEREO)	21,22,23
⑦	Test signal ON/OFF button (TEST)	22
⑧	Center level adjust button (CENTER LEVEL)	23
⑨	Rear level adjust button (REAR LEVEL)	23
⑩	Center mode select button (CENTER MODE)	21
⑪	Memory button (MEMORY)	19

No.	Name	Ref. page
⑫	Muting button (MUTING)	15
⑬	Volume control (VOLUME)	14
⑭	Headphone jack (PHONES)	15
⑮	Direct tuning button (DIRECT TUNING)	16
⑯	Speaker select buttons (SPEAKERS)	14
⑰	Band select button (BAND)	16
⑱	FM mode select button (FM MODE)	16
⑲	Input select buttons	14
⑳	Tape/DCC monitor button (TAPE/DCC MONITOR)	14,24
㉑	Delay time adjust button (DELAY TIME) SA-GX550 only	22
㉒	Loudness ON/OFF button (LOUDNESS) SA-GX550 only	15
㉓	Balance control (BALANCE)	15
㉔	Bass control (BASS)	15
㉕	Treble control (TREBLE)	15

Display section

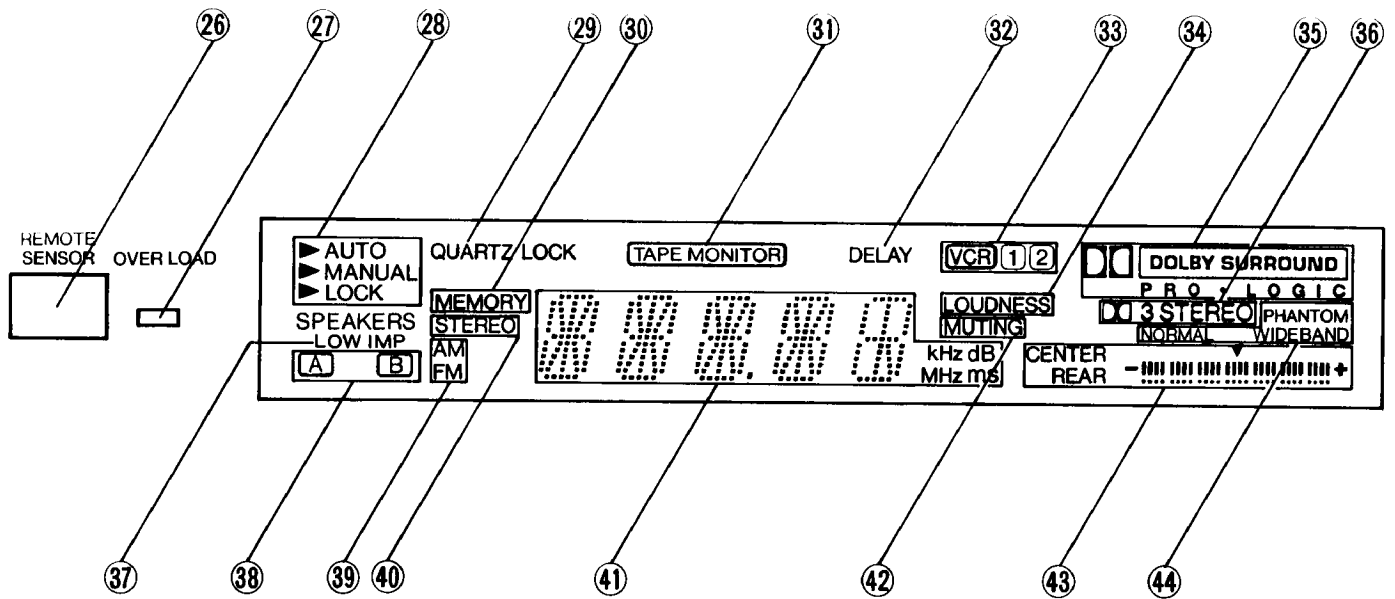

No.	Name	Ref. page
26	Remote control signal receptor	-
27	Overload indicator	27
28	Tuning-mode indicators SA-GX550 only	17
29	Quartz lock indicator	16
30	Memory indicator	19
31	Tape monitor indicator	14,24
32	Delay time indicator SA-GX550 only	22
33	VCR select indicator	25
34	Loudness indicator SA-GX550 only	15
35	DOLBY PRO LOGIC SURROUND indicator	21,22,23
36	DOLBY PRO LOGIC 3 STEREO indicator	21,22,23

No.	Name	Ref. page
37	Low impedance indicator SA-GX550 only	14
38	Speaker select indicators	14
39	Band indicators	16
40	FM stereo indicator	16
41	Input selector/frequency display	-
42	Muting indicator	15
43	Center/rear level display	23
44	Center mode indicators	21

Equipment connections

Connecting audio equipment

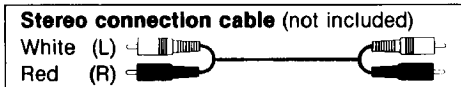

CD changer (or CD player)
(not included)

Tape deck or digital compact cassette deck (DCC)
(not included)

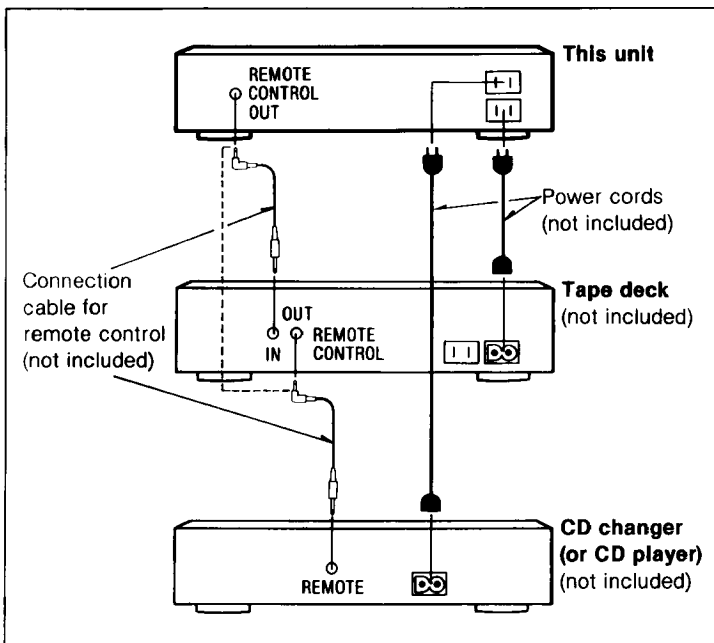
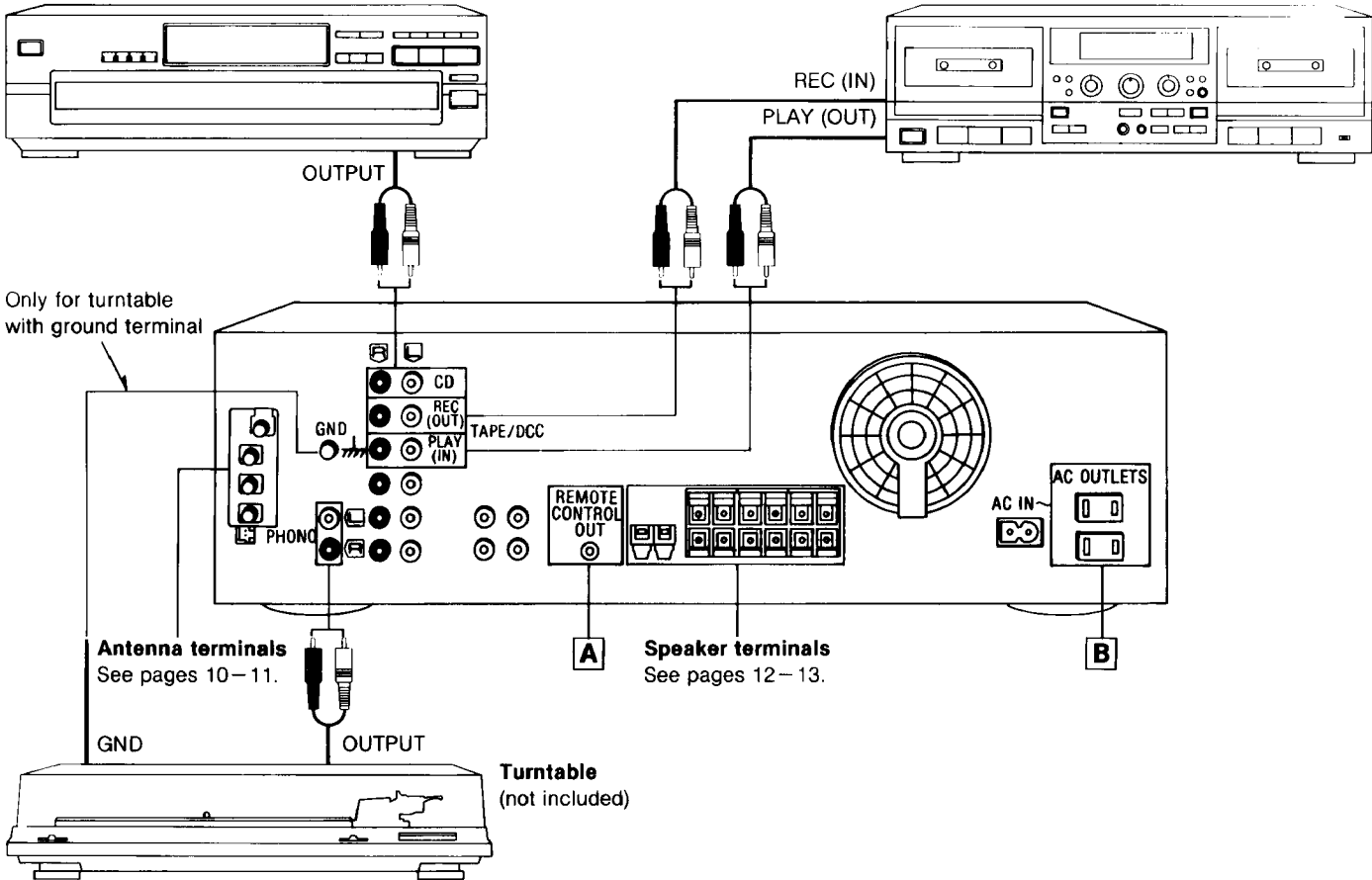

A "REMOTE CONTROL OUT" terminal

Connect the connection cable for remote control to a Technics tape deck and/or CD changer (or CD player) which has the appropriate remote control terminal as shown at the left.

If a tape deck is not being used, the CD changer (or CD player) can be connected directly (dotted line).

B "SWITCHED" AC outlet(s)

Power to these outlets is controlled by the power switch of this unit. Audio equipment rated up to the indicated power ratings can be connected here.

For proper remote-control operation

For SA-GX550

Connect the power cords of the tape deck and CD changer (or CD player) to these outlets as shown at the left.

For SA-GX350

Because there is only one AC outlet, connect the power cord of the CD changer (or CD player) to the AC outlet of the tape deck.

Connecting video equipment

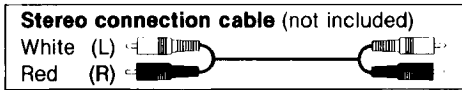

Second VCR (for playback only)
 (not included)

Monitor TV
 (not included)

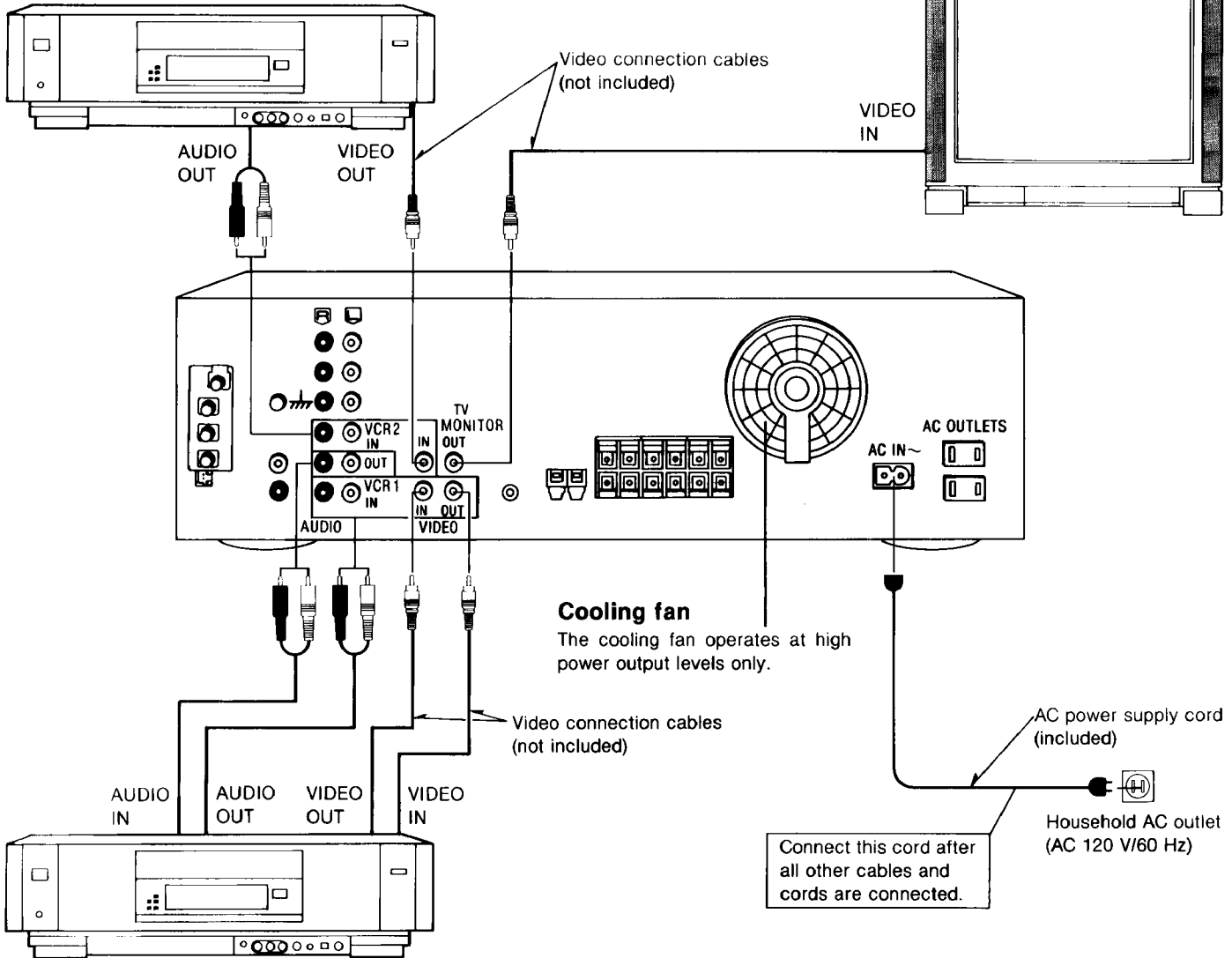

VCR
 (not included)

Antenna connections

FM indoor antenna (included)

This antenna is normally sufficient for reception of FM broadcasts.

FM indoor antenna (included)

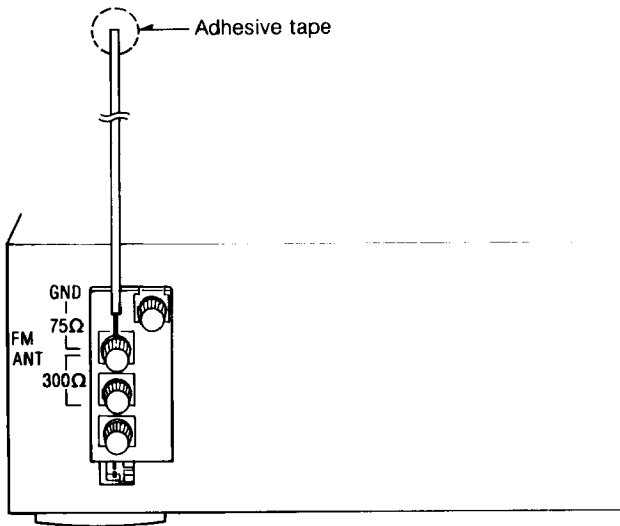

Attach to a wall (using a tape) facing in the direction of best reception.

How to connect an FM indoor antenna

- 1 Pull off the plastic on the tip of the antenna wire.
- 2 Twist the wire and connect as shown below.

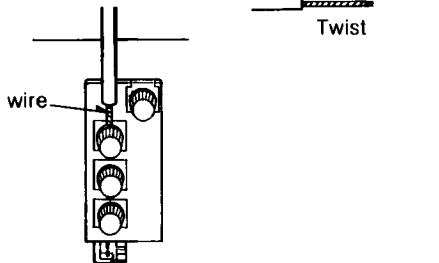

For best reception sound quality:

An FM outdoor antenna is recommended. Disconnect the antenna if an FM outdoor antenna is installed.

FM outdoor antenna (not included)

The outdoor antenna should be used when using the main unit in mountainous areas or in spaces enclosed by reinforced concrete where the FM indoor antenna (included) does not provide satisfactory reception.

FM outdoor antenna (not included)

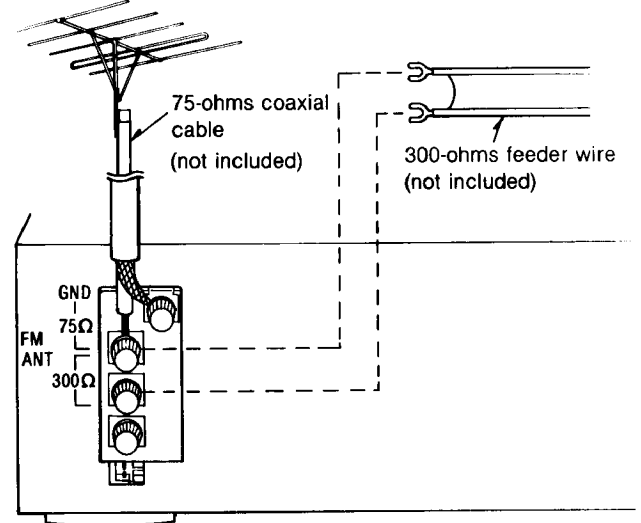

Note

An outdoor antenna should be installed by a qualified technician only.

How to connect a 75-ohms coaxial cable

- 1 Remove a piece of the outer vinyl insulator.

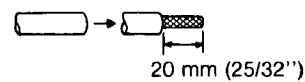

- 2 Twist the shield braid to expose the core wire.

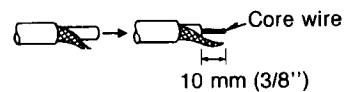

- 3 Connect the shield braid and the core wire as shown at the right.

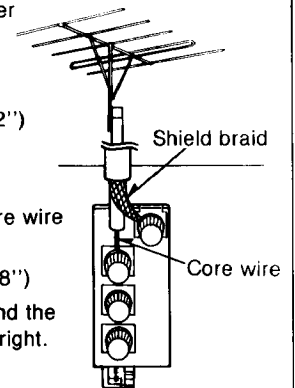

Connection wire from the antenna

Two types of wire are most commonly used for connection from the antenna: 300-ohms parallel feeder wire or 75-ohms coaxial cable. For best resistance to external interference noise, the use of 75-ohms coaxial cable is suggested.

AM loop antenna (included)

This antenna is normally sufficient for reception of AM broadcasts.

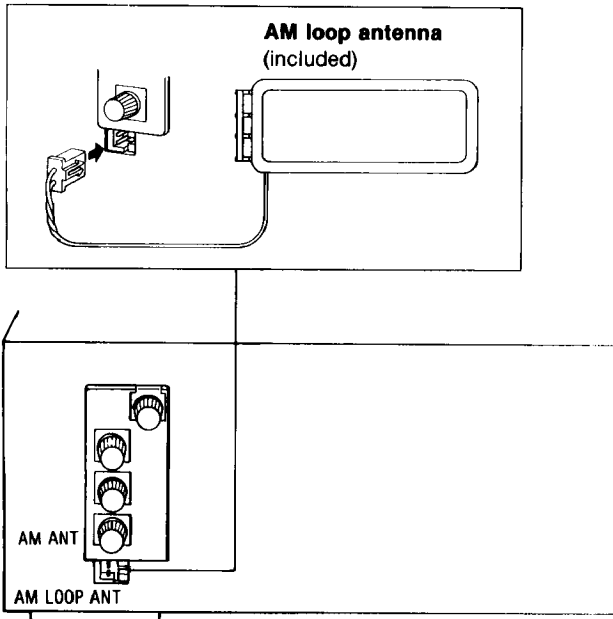

Connect the AM loop antenna to the AM loop antenna terminals, and mount it vertically to the rear panel of this unit.

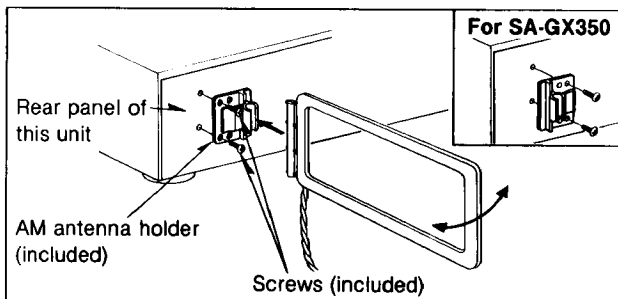

Pay attention to the following points when mounting the antenna.

- Do not mount it horizontally (Doing so will impair reception).
- Do not mount it close to power cords, speaker wires or metal surfaces (Doing so will result in noise).
- Do not mount it close to a tape deck. When the tape deck is being used, chirping or beeping sounds may result.

When mounting the antenna to a column, a wall or rack

Mount it vertically.

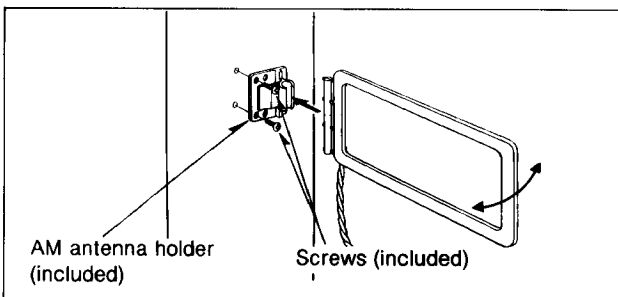

AM outdoor antenna (not included)

The outdoor antenna should be used when using the main unit in mountainous areas or in spaces enclosed by reinforced concrete where the AM loop antenna (included) does not provide satisfactory reception.

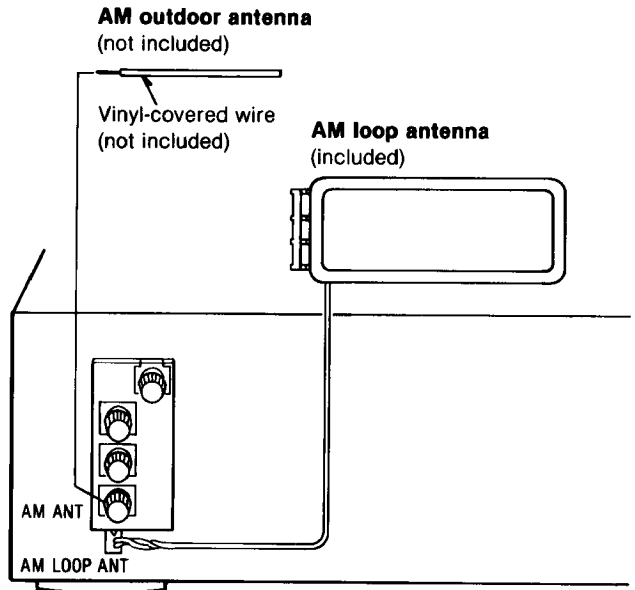

Use 5–12 m (16–40 ft.) of vinyl-covered wire horizontally at the window, or convenient location.

When the unit is not in use, disconnect the outdoor antenna to prevent possible damage that may be caused by lightning. Never use an outdoor antenna during an electrical storm.

Note

Be sure to connect the AM loop antenna even when an outdoor antenna is used.

Speaker connections

Placement of speakers

As well as enjoying normal stereo reproduction with both the left and right front speakers connected, a center speaker and rear speakers can also be connected to the main unit in order to enjoy playback with a feeling of presence using the Dolby Pro-Logic Systems.

The illustration below shows where to place the speakers when enjoying sound with Dolby Pro-Logic systems.

The listening position at which the effect is the greatest is a position slightly to the rear of a center position of five-speaker systems.

However the position should be adjusted to your personal preference, because the effect varies to some degree depending upon the type of music and the music source.

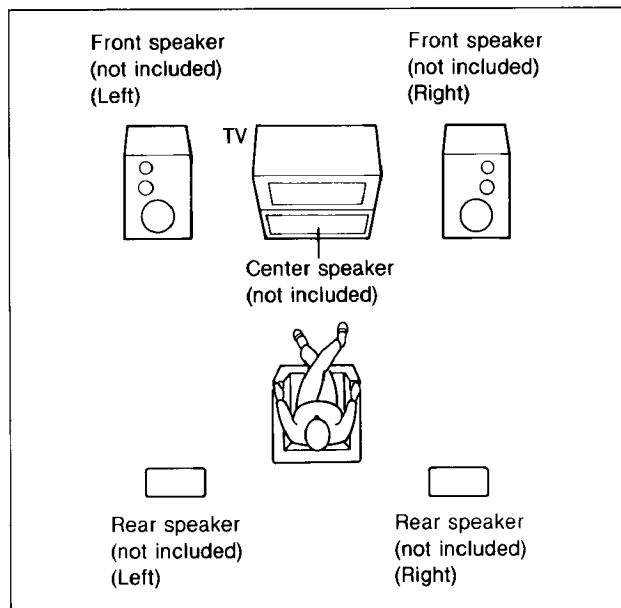

Connection of front speakers

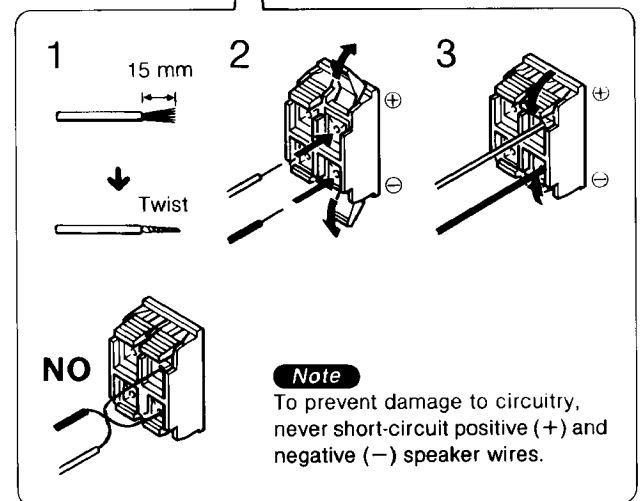
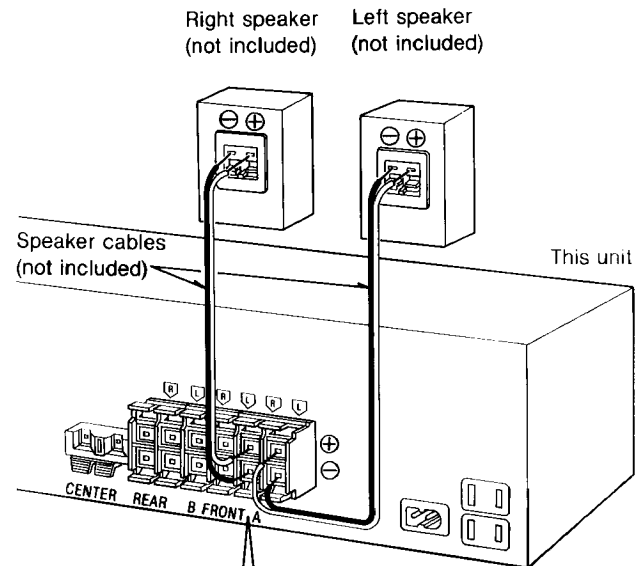

■ "B" terminals

For connection to a second pair of speakers.

■ Speaker impedance

For SA-GX550

When only the "A" or only the "B" speakers are connected:

The impedance of the speaker used with this unit must be 4–8 Ω .

Note

If 4 Ω speakers are connected, be sure to set the impedance on the main unit to LOW according to step 2 on page 14.

When both the "A" and the "B" speakers are connected simultaneously:

The impedance of the speaker used with this unit must be 8 Ω .

For SA-GX350

The impedance of any speaker used with this unit must be 8 Ω .

Connection of rear speakers

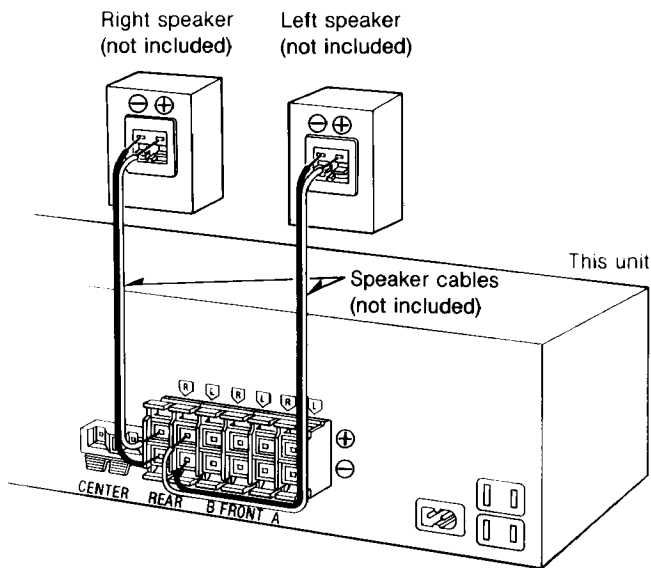

Note
 Sound will only come out when the SURROUND mode of the Dolby Pro-Logic System is on.
 If only one of the rear speakers is connected, no sound will come out. Be sure to connect both speakers.

■ Speaker impedance

The impedance of any speaker used with this unit must be 8 Ω.

Connection of center speaker

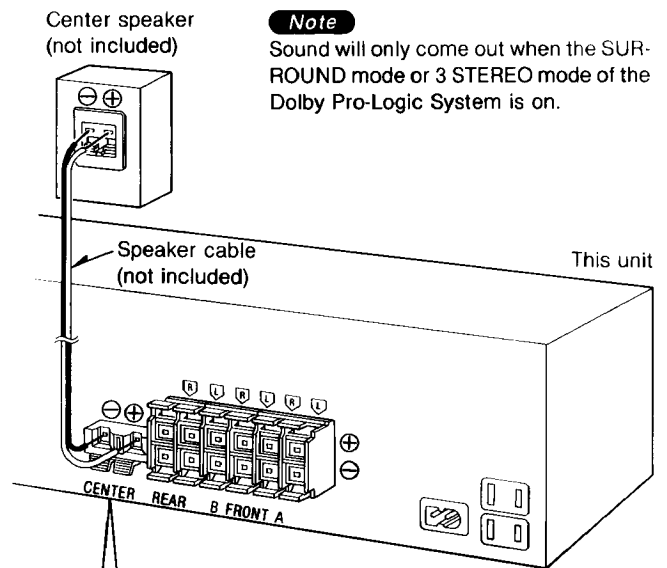

Note
 Sound will only come out when the SURROUND mode or 3 STEREO mode of the Dolby Pro-Logic System is on.

Note
 To prevent damage to circuitry, never short-circuit positive (+) and negative (-) speaker wires.

■ Speaker impedance

The impedance of any speaker used with this unit must be 8 Ω.

Basic operations

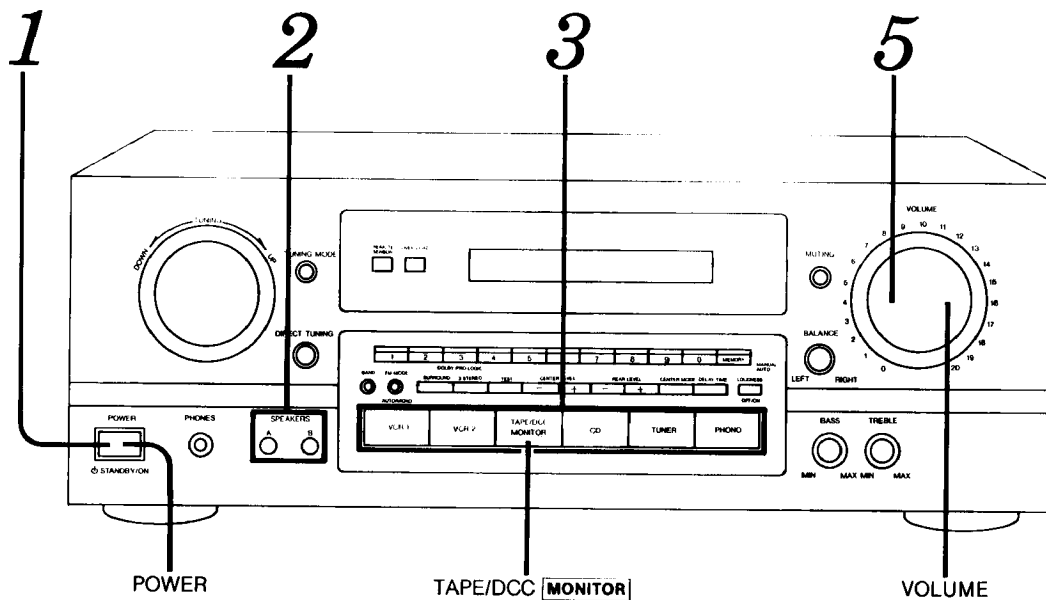

Before operation, set VOLUME to the "0" position.

1 **POWER** Press **POWER** to switch on the power.

2 **SPEAKERS** Press **A** and/or **B** to select the speaker system(s) to be used. A and B refer to the speaker terminals at the rear of the unit.



Illuminates

If the button is pressed once more, the indicator will switch off and no sound will be heard from the speakers.

For SA-GX550 only

When using speakers with an impedance of 4 Ω, press either button A or button B for 4 seconds or more to set the impedance on the main unit to LOW.

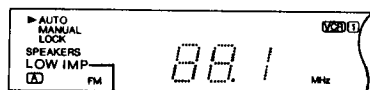

Illuminates

In this condition, speakers A and B cannot both be used at the same time.

3 Press to select the desired source.

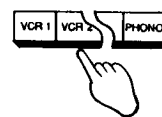

VCR 1: To watch video tapes (VCR 1)

VCR 2: To watch video tapes (VCR 2)

TAPE/DCC MONITOR: To listen to tape or digital compact cassette (DCC) The tape monitor indicator will appear. (See below.)

CD: To listen to compact discs

TUNER: To listen to radio broadcasts

PHONO: To listen to phono discs

4 Start the desired source. (Refer to the appropriate operating instructions for details.)

5 Turn **VOLUME** to adjust the volume level.

After listening is finished

Be sure to reduce the volume level, and switch the power to the standby condition by pressing **POWER**.

When tape monitor indicator illuminates or is flashing (approx. 3 seconds)

This indicates that the tape monitor function of this unit is ON. To listen to sources other than a tape or DCC, be sure to turn off the indicator by pressing **TAPE/DCC MONITOR**.

Illuminates or flashing

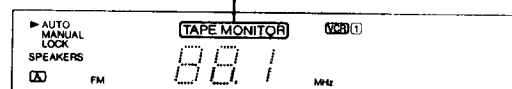

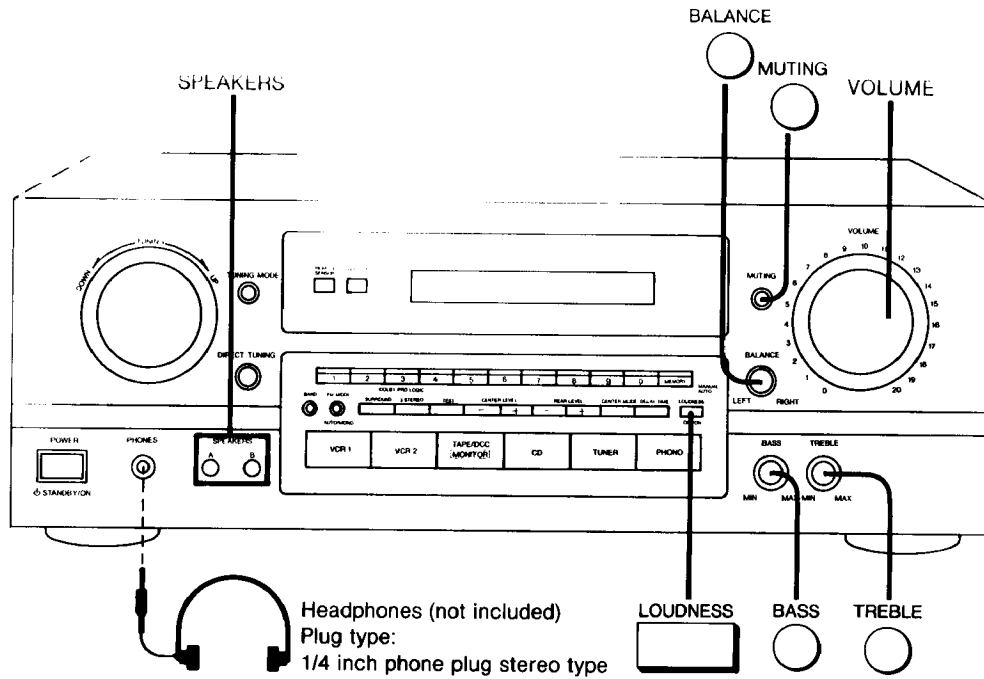

Headphones (not included)
Plug type:
1/4 inch phone plug stereo type

To listen to a desired audio source while watching video picture

1. Follow steps 1–2 at the left.
2. Select the desired video source and audio source in step 3 at the left.
Be sure to select the video source first.
3. Start the video and audio source.

To emphasize low-frequency sound SA-GX550 only

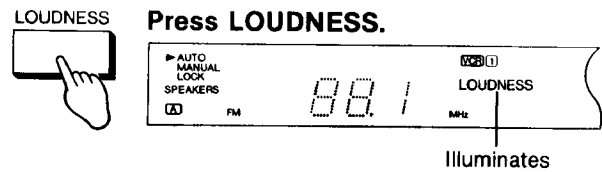

Press **LOUDNESS**.

Press once again to turn it off.

To adjust the sound balance

BALANCE Turn **BALANCE** to adjust the left/right sound balance.

To adjust the tone quality

BASS Turn **BASS** to adjust the low-frequency sound.

TREBLE Turn **TREBLE** to adjust the high-frequency sound.

To mute the sound level

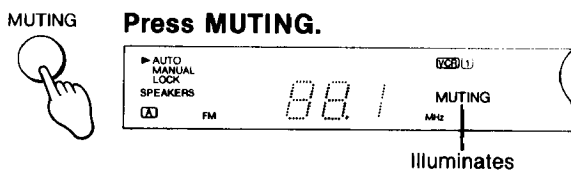

Press **MUTING**.

The volume level is attenuated by approx., 20 dB (1/10).

Press once again to return to the previous volume level. (The muting indicator will turn off.)

When listening through headphones

Use **VOLUME** to reduce the volume level, and connect the headphones.

If sound from speakers is not wanted, press **SPEAKERS** (A) and/or (B) to turn off the speaker select indicators.

Note

Avoid listening for prolonged periods of time to prevent hearing damage.

Listening to radio broadcasts

Direct access tuning

Specify the frequency using the numeric buttons to directly tune to the desired broadcast station.

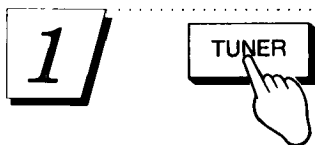
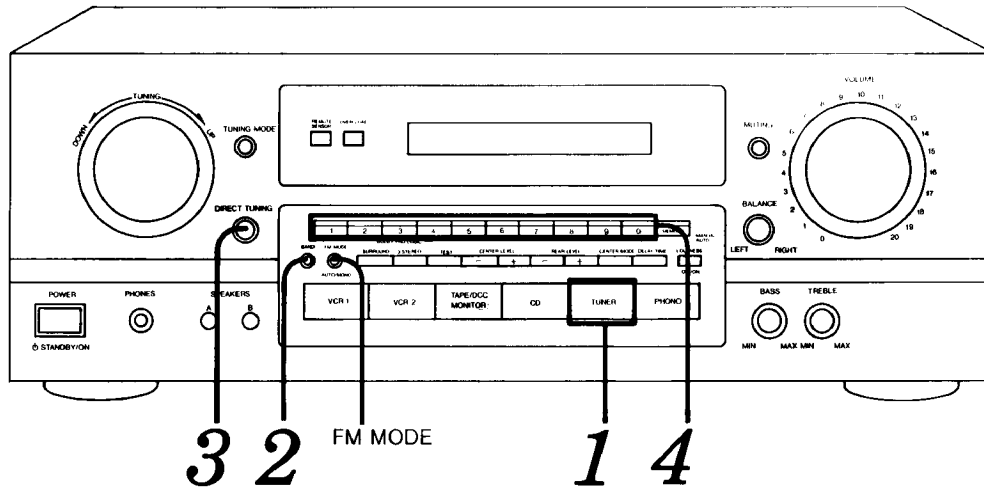

Press TUNER.

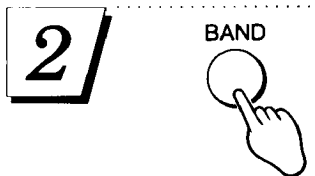

Press BAND to select "FM" or "AM".

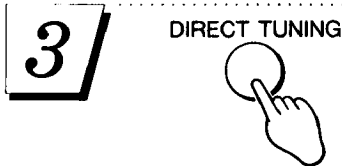
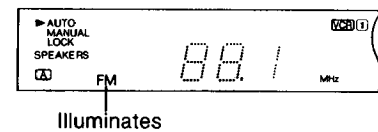

Press DIRECT TUNING.



While cursor display is flashing (approx. 4 seconds)

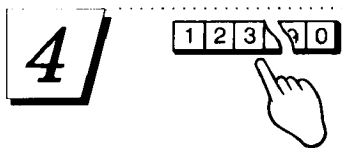

Press the appropriate numeric buttons to enter the frequency.

FM frequencies can be entered at tuning intervals of 100 kHz, and AM frequencies at tuning intervals of 10 kHz.

Note
If no button is pressed while the cursor display is flashing, the display will return to the frequency which is currently being received. To re-specify the frequency, repeat the procedure from step 3.

If the desired FM frequency is 107.9 MHz

1 → 0 → 7 → 9

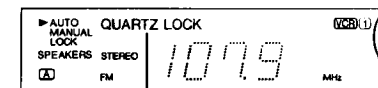

Illuminates when tuned

When the FM stereo broadcast is received:

This unit will automatically switch to FM stereo reception and the FM stereo indicator will illuminate.

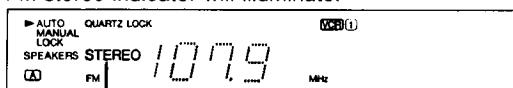

Illuminates

If noise is excessive in the FM stereo mode

Press FM MODE. (The FM stereo indicator will switch off.) The broadcast will be monaural, but noise will be reduced. If the button is pressed once more, stereo mode will be resumed.

Sequential tuning **For SA-GX550**

If the frequency is not known, use the tuning control for searching.

Auto tuning

This automatically searches for broadcast stations which provide strong signal reception.

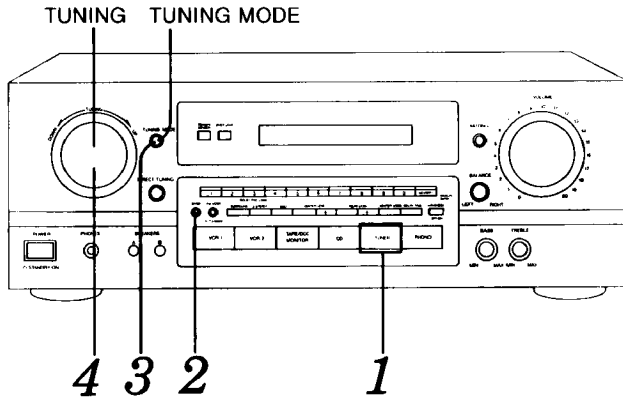

- 1/** **Press TUNER.**
- 2/** **Press BAND to select "FM" or "AM".**
- 3/** **Press TUNING MODE to select "AUTO".**
 The ► mark points to AUTO.
- 4/** **Turn TUNING until the frequency begins to change.**
 Automatically stops when a broadcast station is found.

Note
Tuning may stop automatically if any jamming is encountered.

Manual tuning

The frequency will change only by the amount that the tuning control is turned.

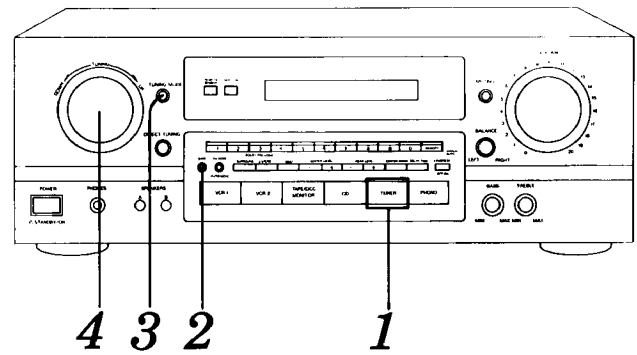

- 1/** **Press TUNER.**
- 2/** **Press BAND to select "FM" or "AM".**
- 3/** **Press TUNING MODE to select "MANUAL".**
 The ► mark points to MANUAL.
- 4/** **Turn TUNING to tune to the desired broadcast.**
 Turn until the desired broadcast station is obtained.
Tuning intervals
 FM: 200 kHz interval
 AM: 10 kHz interval

To lock a broadcast station being received

Press TUNING MODE to select "LOCK".
The ► mark points to LOCK.

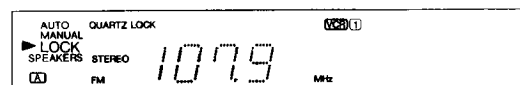

During this display, the frequency will not change even if TUNING is turned.

Automatic memory presetting

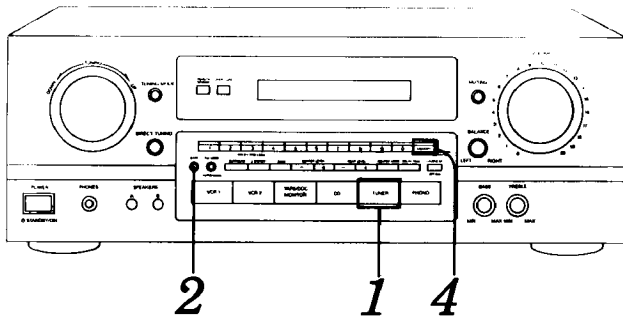

- 1/ **TUNER** Press TUNER.
- 2/ **BAND** Press BAND to select "FM" or "AM".
- 3/ Set to the frequency from which you want to start automatic memory presetting. (Refer to page 16.)
- 4/ **MEMORY** Press MEMORY until the frequency begins to change. (Automatic memory presetting will start.)
To stop press MEMORY once again.

When a broadcast station is preset

The memory indicator and the preset channel number will be displayed for approximately 1 second.

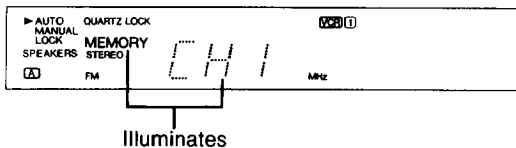

When presetting is completed

The last broadcast station to be preset will be displayed.

Note

Correct presetting may not be possible in cases where the broadcast waves are too strong or too weak. In such cases, carry out presetting manually.

Manual memory presetting

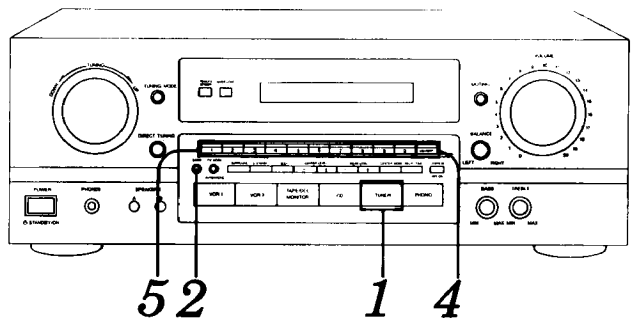

- 1/ **TUNER** Press TUNER.
- 2/ **BAND** Press BAND to select "FM" or "AM".
- 3/ Set to the desired broadcast. (Refer to pages 16–18.)
- 4/ **MEMORY** Press MEMORY momentarily.
Illuminates
To cancel the memory function, press MEMORY again.

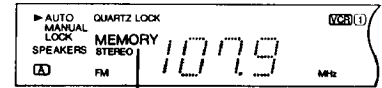

- 5/ **1 2 3 7 0** Specify the desired channel to be preset using the numeric button(s) (completes presetting). (Example: Channel 12)

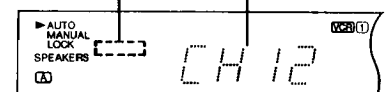
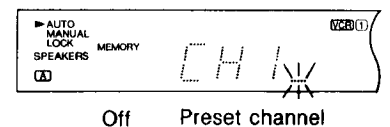
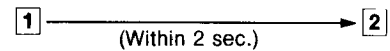

To continue presetting

Repeat steps 2 through 5.

Preset tuning (continued)

To listen to preset broadcast stations

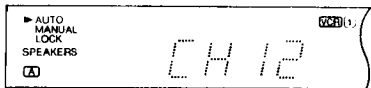
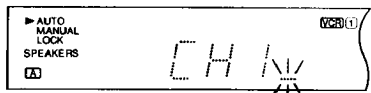
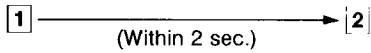
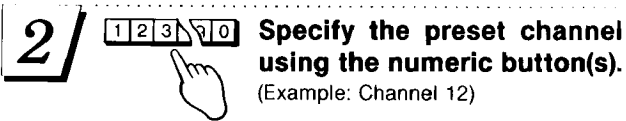
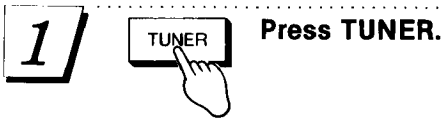
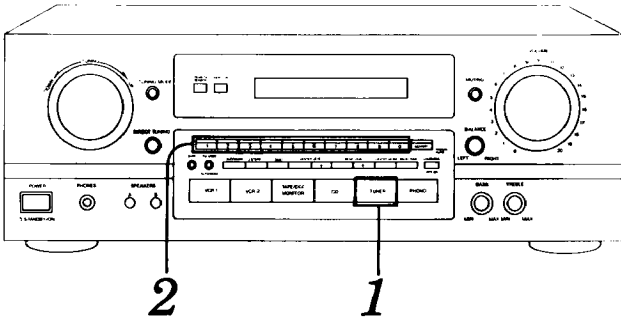

For your reference:

Even if the power is switched to the standby condition or the power cord is disconnected from the household AC outlet, the contents of the memory will continue to be stored for approximately one month.

If frequency presettings are accidentally erased

Make the frequency presettings once again.
The power cord should remain connected for one hour or more for the memory back-up to be effective.

Enjoying sound with DOLBY PRO LOGIC

By combining front (A or B), center and rear speakers, SURROUND mode which conveys a feeling of presence or 3 STEREO mode which conveys a feeling of orientation can be enjoyed.

SURROUND

By reproducing the feeling of depth and movement of sound, video software or compact discs recorded with Dolby Surround provide the listener with a feeling of presence like that of a movie theater.

To enjoy SURROUND, be sure to connect the rear speakers.

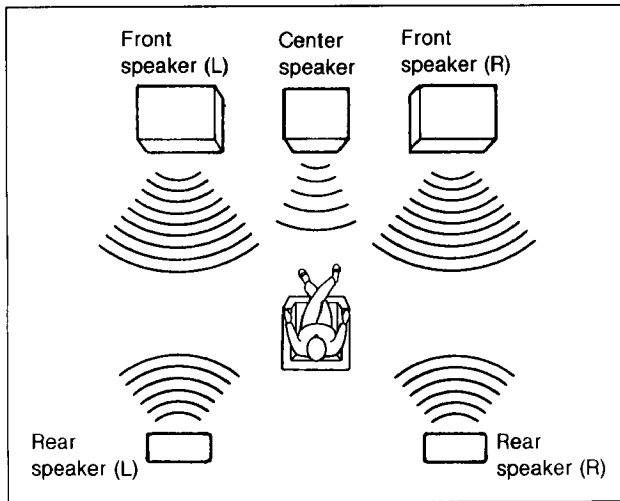

3 STEREO

Music and news programs with clear sound and a good feeling of orientation can be enjoyed.

To enjoy 3 STEREO, be sure to connect the center speaker.

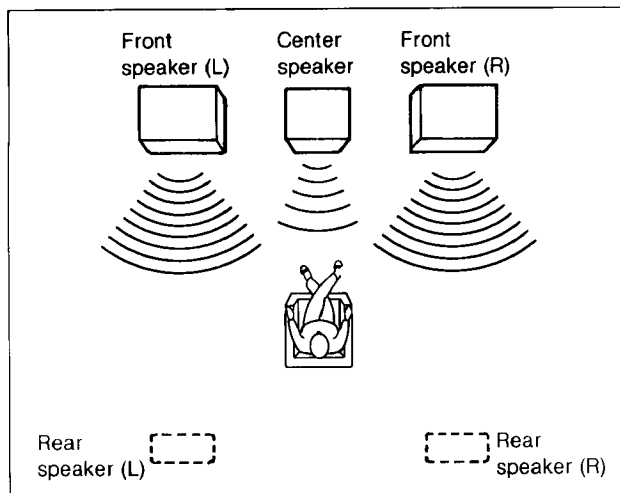

Manufactured under license from Dolby Laboratories Licensing Corporation. Additionally licenced under one or more of the following patents: U.S. numbers 3,632,886, 3,746,792 and 3,959,590; Canadian numbers 1,004,603 and 1,037,877. "Dolby" and the double-D symbol are trademarks of Dolby Laboratories Licensing Corporation.

Setting the center mode

For Dolby Pro-Logic systems, center mode setting is necessary to play back bass sounds effectively.

Set the center mode in accordance with the size of your center speaker.

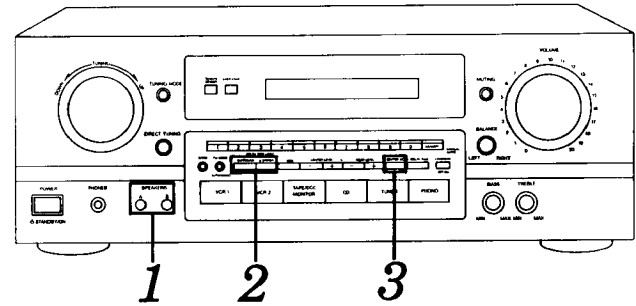

1/ SPEAKERS A B
Press A or B to select the speaker system to be used.

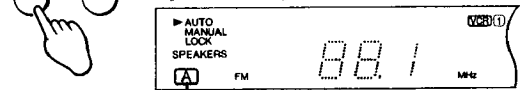

Illuminates

2/ SURROUND
Press SURROUND or 3 STEREO to turn on the desired mode.

For SURROUND mode

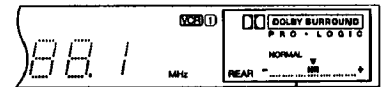

Illuminates

For 3 STEREO mode

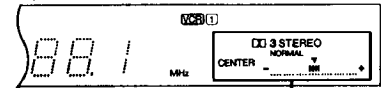

Illuminates

Press once again to turn it off.

3/ CENTER MODE
Press CENTER MODE to select the correct center mode.

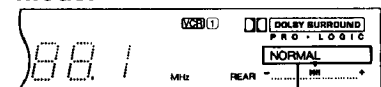

The indicator changes each time the button is pressed.

NORMAL:

When the center speaker is smaller than the front speakers

WIDE BAND:

When the center speaker is the same size as the front speakers

PHANTOM: SURROUND only

When no center speaker is connected.

Note

In the PHANTOM mode, the sound from the center speaker will be divided between both the left and right front speakers.

Adjusting the delay time

SA-GX550 only

When enjoying with SURROUND only

Adjust so that the sound from the rear speakers is correctly oriented.

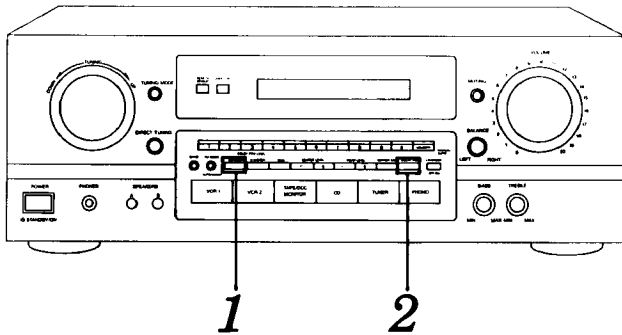

1 **SURROUND** Press SURROUND to turn on the SURROUND mode.

2 **DELAY TIME** Press DELAY TIME to set to the suitable time.

Illuminates

To calculate the delay time, refer to the calculation methods below.

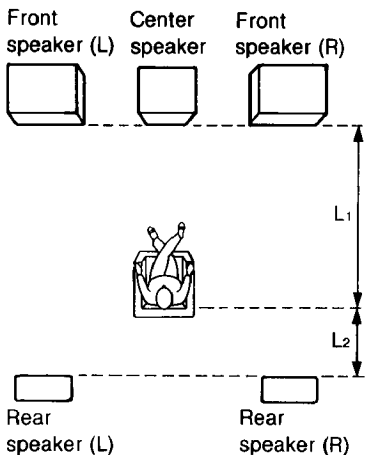

- If $L_1 \leq L_2$
Set to 15 ms.
- If $L_2 < L_1$
Start at 15 ms and increase by 5 ms for every 5 feet of difference between L_1 and L_2 .

Adjusting the output level of each speaker

In order to reproduce the feeling of movement of the sound and clear orientation of sound, it is important to correctly adjust the output levels of each speaker. Adjust to the correct levels while listening to the test signal.

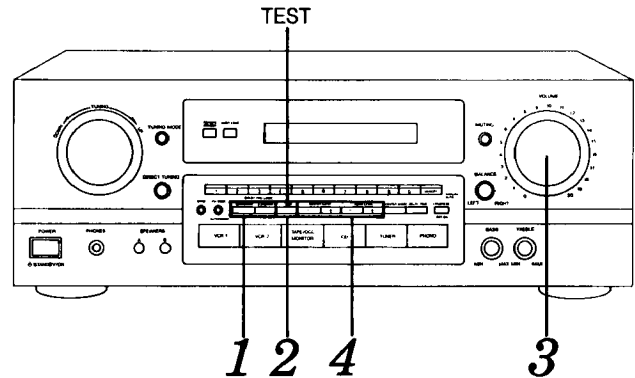

1 **SURROUND** Press SURROUND or 3 STEREO to turn on the desired mode.

For SURROUND mode

or

3 STEREO For 3 STEREO mode

Press once again to turn it off.

2 **TEST** Press TEST to output a test signal.

Test signal sounds sequentially as follows:

For SURROUND mode

```

    Front speaker (left) → Center speaker (left)
    ↑                               ↓
    Rear speakers (left, right) ← Front speaker (right)
    
```

For 3 STEREO mode

```

    Front speaker (left) → Center speaker (left)
    ↑                               ↓
    Front speaker (right) ←
    
```

(Continued on next page)

3 **VOLUME** Turn **VOLUME** to set the volume level normally used for enjoying the source.

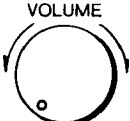

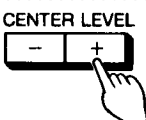

4 **CENTER LEVEL** Press **CENTER LEVEL (-)** or **(+)** or **REAR LEVEL (-)** or **(+)** to adjust the output level balance.



SURROUND only

REAR LEVEL While standing in the listening area, adjust the output levels of each speaker until they are all identical.

 : Decrease the output level.
 : Increase the output level.

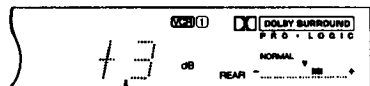



The output levels can be varied within a range of -12 dB to +12 dB according to the output levels from the front speakers.

TEST To stop the test signal Press **TEST**.

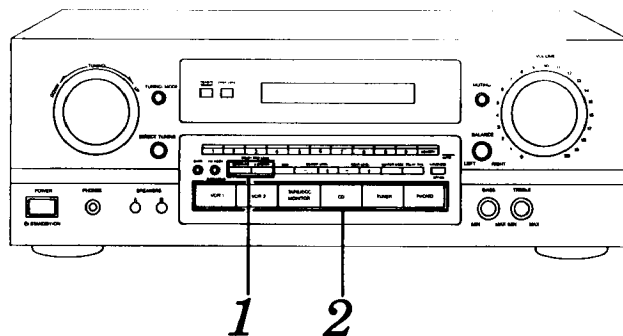

Enjoying with **SURROUND** or **3 STEREO**



1 **SURROUND** Press **SURROUND** or **3 STEREO** to turn on the desired mode.

For **SURROUND** mode

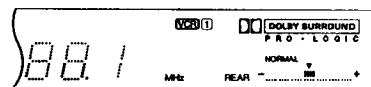

or

For **3 STEREO** mode

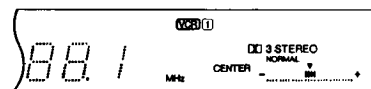

Press once again to turn it off.

2 **VCR 1 VCR 2 PHONO** Select the desired source.



3 Start the desired source.

Note

When employing **SURROUND**, use software which has been recorded with Dolby Surround.

Making a recording

Tape recording on the tape deck or digital compact cassette (DCC)

Before recording, prepare the tape deck or DCC for recording (recording level adjustment, etc.).
See the tape deck's or DCC's operating instructions for details.

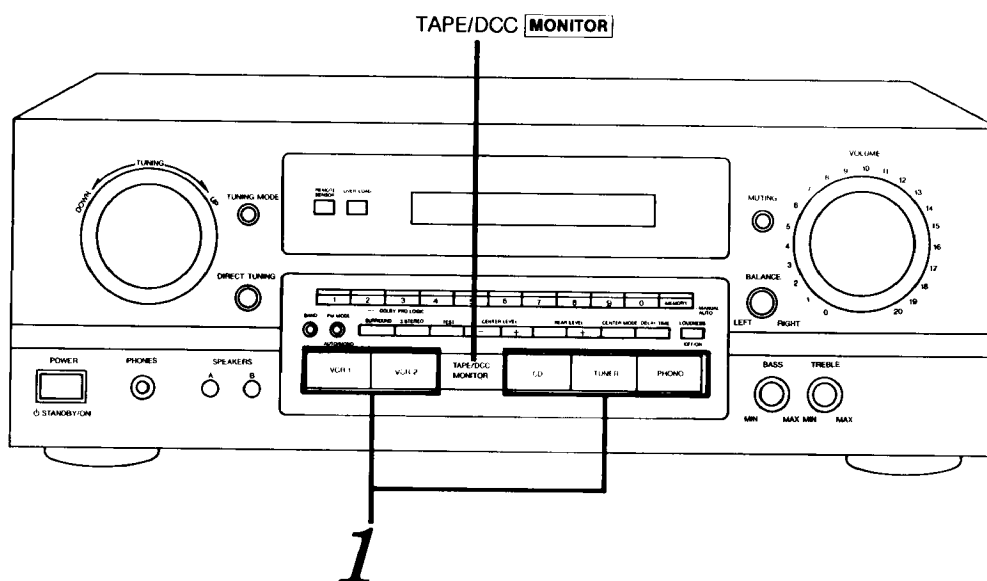

1

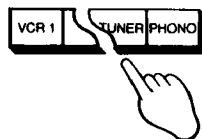

Select the audio/video source to be recorded.

2

Begin recording.

Follow your tape deck's or DCC's operating instructions.

3

Begin the audio/video source to be recorded.

To check the sound recorded while recording is being made

With a tape deck with 3 heads, it is possible to check the sound recorded on the tape.

Press TAPE/DCC **MONITOR** on this unit and set the monitor button on the tape deck to "TAPE".

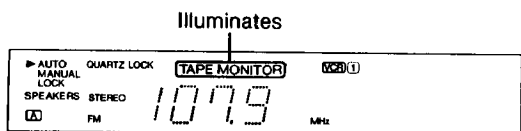

Press TAPE/DCC **MONITOR** once again to turn it off.

Recording from VCR 2 to VCR 1

Before recording, prepare the VCR (VCR 1) for recording (recording level adjustment, etc.).
See the VCR's operating instructions for details.

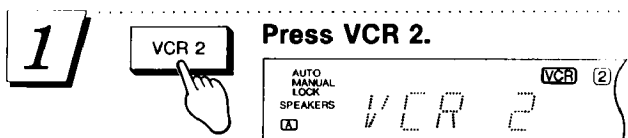
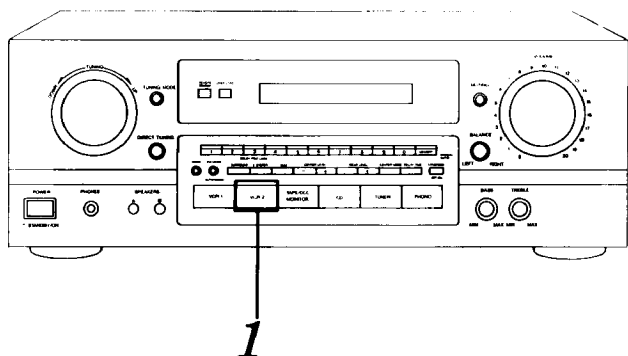

2/ Begin recording on the VCR 1 and playback the tape on the VCR 2.

Follow your VCR's operating instructions.

For your reference:

If a laser disc player is connected to the "VCR 2" terminals, recording from the laser disc player is possible by following the above procedure.

VCR (VCR 1) recording from an audio source

Before recording, prepare the VCR (VCR1) for recording (recording level adjustment, input selector setting, etc.).
See the VCR's operating instructions for details.

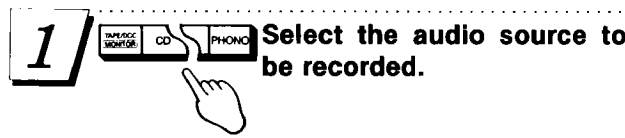
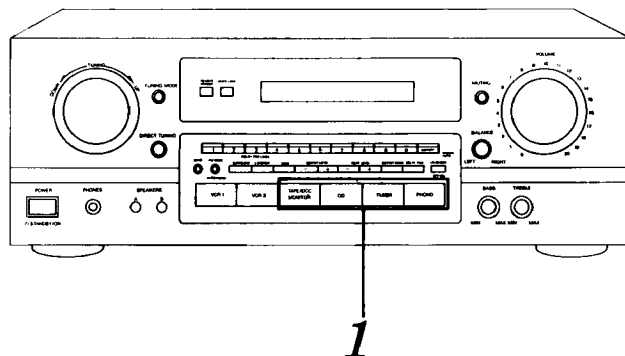

2/ Begin recording on the VCR 1.

Follow your VCR's operating instructions.

3/ Begin the audio source to be recorded.

To record picture from VCR 2 and sound from a different audio source

Before recording, prepare the VCR (VCR 1) for recording (recording level adjustment, input selector setting, etc.). See the VCR's operating instructions for details.

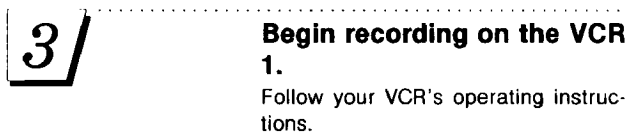
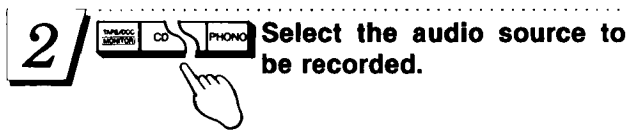
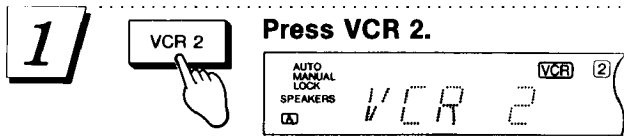
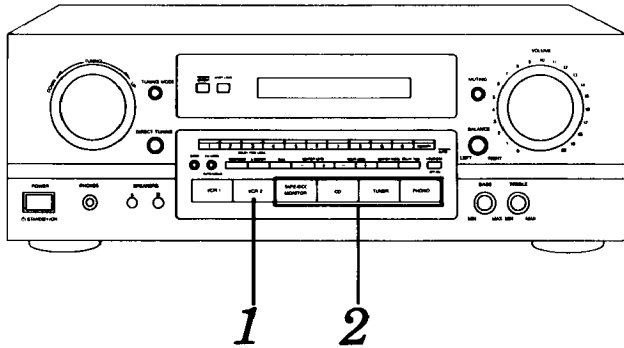

For your reference:

If a laser disc player is connected to the "VCR 2" terminales, recording picture from the laser disc player is possible by following the above procedures.

Do not attempt to remove the cover(s) or repair the unit yourself. Refer servicing to qualified personnel only.

Product information

For product service, product information or assistance with product operation, refer to the servicenter directory.

Troubleshooting guide

Before requesting service for this unit, check the chart below for a possible cause of the problem you are experiencing. Some simple checks or a minor adjustment on your part may eliminate the problem and restore proper operation.

If you are in doubt about some of the check points, or if the remedies indicated in the chart do not solve the problem, refer to the directory of authorized service centers (enclosed with this unit) to locate a convenient service center, or consult your Technics dealer for instructions.
(In U.S.A. consult MSC Authorized Servicenters for detailed instructions.)

Problem	Probable cause(s)	Suggested remedy
---------	-------------------	------------------

While listening to FM broadcasts		
An unusual hissing noise is heard when listening to the broadcast in stereo, but not heard when listening monaurally.	A slight noise may be heard because the method used for modulation of FM stereo broadcasts is different than that used for monaural broadcasts.	<ul style="list-style-type: none"> • Try reducing the treble sound by using the treble control. • Try changing the location, height and/or direction of the antenna. • If an indoor antenna is being used, change to an outdoor antenna. • Try using an antenna with more elements.
Noise is excessive in both stereo and monaural broadcasts.	Poor location and/or direction of the antenna. Transmitting station is too far away.	<ul style="list-style-type: none"> • Try changing the location, height and/or direction of the antenna. • If an indoor antenna is being used, change to an outdoor antenna. • Try using an antenna with more elements.
The FM stereo indicator or the quartz lock indicator flickers, without completely illuminating.	Poor location and/or direction of the antenna. Transmitting station is too far away.	<ul style="list-style-type: none"> • Try changing the location, height and/or direction of the antenna. • If an indoor antenna is being used, change to an outdoor antenna. • Try using an antenna with more elements.
Excessive distortion in the sound of stereo broadcasts.	Nearby building or mountain.	<ul style="list-style-type: none"> • Try using an antenna with more elements.

While listening to AM broadcasts		
An unusual "beat" sound is heard.	Unit is being used at the same time as the television set. Interference from adjacent broadcast signal.	<ul style="list-style-type: none"> • Turn off the television set, or use this unit farther away from it. • Try reducing the treble sound by using the treble control.
A low-pitched "hum" sound is heard when the broadcast is tuned.	The AM loop antenna connection wires are too close to the power cord. The power supply frequency from the power cord is modulated and heard from the speakers.	<ul style="list-style-type: none"> • Place the antenna connection wires and the power cord farther apart. • Install a special outdoor antenna.
A strange hissing noise is produced continuously or intermittently.	Caused by the "discharge phenomenon" and the "oscillation phenomenon" of electric appliances (such as fluorescent lights, TV, small series-type motors, rectification equipment, etc.).	<ul style="list-style-type: none"> • Try placing this unit farther away from such equipment. • Install noise-prevention equipment on this unit or on the electric appliance.

While enjoying sound with DOLBY PRO LOGIC		
The DOLBY PRO LOGIC (SURROUND or 3 STEREO) indicator will flash.	When the Dolby Pro Logic system is ON, both A and B speakers are turned ON.	<ul style="list-style-type: none"> • When the Dolby Pro Logic system is ON, A and B speakers cannot both be used simultaneously.

Problems noted at all times		
Power will not switch ON.	The power cord plug is not completely inserted.	<ul style="list-style-type: none"> • Confirm that the power cord plug is connected completely.
No sound is heard when the power is switched ON.	Connections are incomplete or incorrect to the speaker systems, etc. The incorrect input selector has been pressed. The speaker select indicators are turned off.	<ul style="list-style-type: none"> • Check to be sure that all connection wires are correctly connected. • Check to be sure that the correct selector is pressed. • Turn on the speaker select indicator(s).
Sound stops during a performance, or no sound is heard when the power is switched ON. (Over load indicator is illuminated.)	The protection circuitry has functioned because the positive and negative speaker connection wires are "shorted", speaker systems with an impedance less than the indicated rated impedance of this unit are used or under severe use, such as loud volume, excessive power and in an excessively hot environment.	<ul style="list-style-type: none"> • Switch off the power, and after determining and correcting the cause, switch on the power once again. • Use a speaker system of the proper impedance rating.
Speaker select indicators (A), (B) are flashing.	When both A and B speakers are being used simultaneously, the Dolby Pro Logic system is turned ON.	<ul style="list-style-type: none"> • When both A and B speakers are being used simultaneously, the Dolby Pro Logic system cannot be enjoyed.

Technical specifications (IHF'78)

■ AMPLIFIER SECTION

Rated minimum sine wave

RMS power output

20 Hz—20 kHz both channels driven

0.05% total harmonic distortion

[SA-GX350] 100 W per channel (8 Ω)

[SA-GX550] 110 W per channel (8 Ω)

1 kHz continuous power output

both channels driven

0.05% total harmonic distortion

[SA-GX350] 103 W per channel (8 Ω)

[SA-GX550] 115 W per channel (8 Ω)

Total harmonic distortion

rated power at 20 Hz—20 kHz 0.05% (8 Ω)

half power at 1 kHz 0.03% (8 Ω)

Power output at the Dolby Pro Logic operation

Power output (Front) 0.8% at 1 kHz

[SA-GX350] 2 × 50 W (8 Ω)

[SA-GX550] 2 × 75 W (8 Ω)

Power output (Center) 0.8% at 1 kHz

[SA-GX350] 50 W (8 Ω)

[SA-GX550] 75 W (8 Ω)

Power output (Rear) 0.8% at 1 kHz

[SA-GX350] 20 W (8 Ω)

[SA-GX550] 30 W (8 Ω)

Dynamic headroom

1.2 dB (8 Ω)

SMPTE intermodulation distortion

0.3% (8 Ω)

Frequency response

PHONO

RIAA standard curve ±0.8 dB

CD, VCR 1, VCR 2, TAPE/DCC

7 Hz—70 kHz, ±3 dB

Input sensitivity

PHONO

0.4 mV (3 mV, IHF '66)

CD, VCR 1, VCR 2, TAPE/DCC

20 mV (200 mV, IHF '66)

S/N (IHF, A)

PHONO

70 dB (80 dB, IHF '66)

CD, VCR 1, VCR 2, TAPE/DCC

[SA-GX350] 75 dB (88 dB, IHF '66)

[SA-GX550] 75 dB (90 dB, IHF '66)

Phono maximum input voltage [SA-GX550 only]

150 mV (IHF '66)

Input impedance

PHONO

47 kΩ

CD, VCR 1, VCR 2, TAPE/DCC

22 kΩ

Tone controls

BASS

50 Hz, +10 dB to -10 dB

TREBLE

20 kHz, +10 dB to -10 dB

Loudness control (volume at -30 dB) [SA-GX550 only]

50 Hz, +9 dB

30 (8 Ω)

Low frequency damping factor

30 (8 Ω)

Load impedance

A or B

[SA-GX350] 8 Ω

[SA-GX550] 4—8 Ω

A and B

8 Ω

■ FM TUNER SECTION

Frequency range

87.9—107.9 MHz

Sensitivity

11.2 dBf (2 μV, IHF '58)

50 dB quieting sensitivity

MONO

18.3 dBf (4.5 μV, IHF '58)

STEREO

38.3 dBf (45 μV, IHF '58)

Total harmonic distortion

MONO

0.2%

STEREO

0.3%

S/N

MONO

75 dB

STEREO

70 dB

Frequency response

20 Hz—15 kHz, +1 dB, -2 dB

Alternate channel selectivity

65 dB

Capture ratio

1 dB

Image rejection at 98 MHz

45 dB

IF rejection at 98 MHz

80 dB

Spurious response rejection at 98 MHz

75 dB

AM suppression

50 dB

Stereo separation

1 kHz

40 dB

10 kHz

30 dB

Carrier leak

19 kHz

-35 dB

38 kHz

-50 dB

Antenna terminals

300 Ω (balanced)

75 Ω (unbalanced)

■ AM TUNER SECTION

Frequency range

530—1710 kHz

Sensitivity

20 μV, 330 μV/m

Selectivity

55 dB

Image rejection at 1000 kHz

40 dB

IF rejection at 1000 kHz

60 dB

■ VIDEO SECTION

Output voltage at 1 V input (unbalanced)

1 ± 0.1 V_{p-p}

Maximum input voltage

1.5 V_{p-p}

■ GENERAL

Power consumption

[SA-GX350] 280 W, 360 VA

[SA-GX550] 320 W, 430 VA

Power supply

AC 120 V, 60 Hz

Dimensions (W × H × D)

[SA-GX350] 430 × 136 × 352 mm

(16-15/16" × 5-11/32" × 13-27/32")

[SA-GX550] 430 × 158 × 352 mm

(16-15/16" × 6-7/32" × 13-27/32")

Weight

[SA-GX350] 8.8 kg (19.4 lb.)

[SA-GX550] 10.7 kg (23.5 lb.)

Notes:

1. Specifications are subject to change without notice. Weight and dimensions are approximate.
2. Total harmonic distortion is measured by the digital spectrum analyzer.

Panasonic Company, Division of
Matsushita Electric Corporation of America
One Panasonic Way
Secaucus, New Jersey 07094

Panasonic Sales Company, Division of
Matsushita Electric of Puerto Rico, Inc.
San Gabriel Industrial Park
65th Infantry Ave. Km. 9.5
Carolina, P.R. 00630

Panasonic Company (West) of America, Division of
Matsushita Electric Corporation of America
6550 Katella Ave.
Cypress, CA 90630

Matsushita Electric of Canada Limited
5770 Ambler Drive, Mississauga,
Ontario L4W 2T3